

Dolphin

Theme: Shaping

Fold using 6" (15 cm) origami paper.

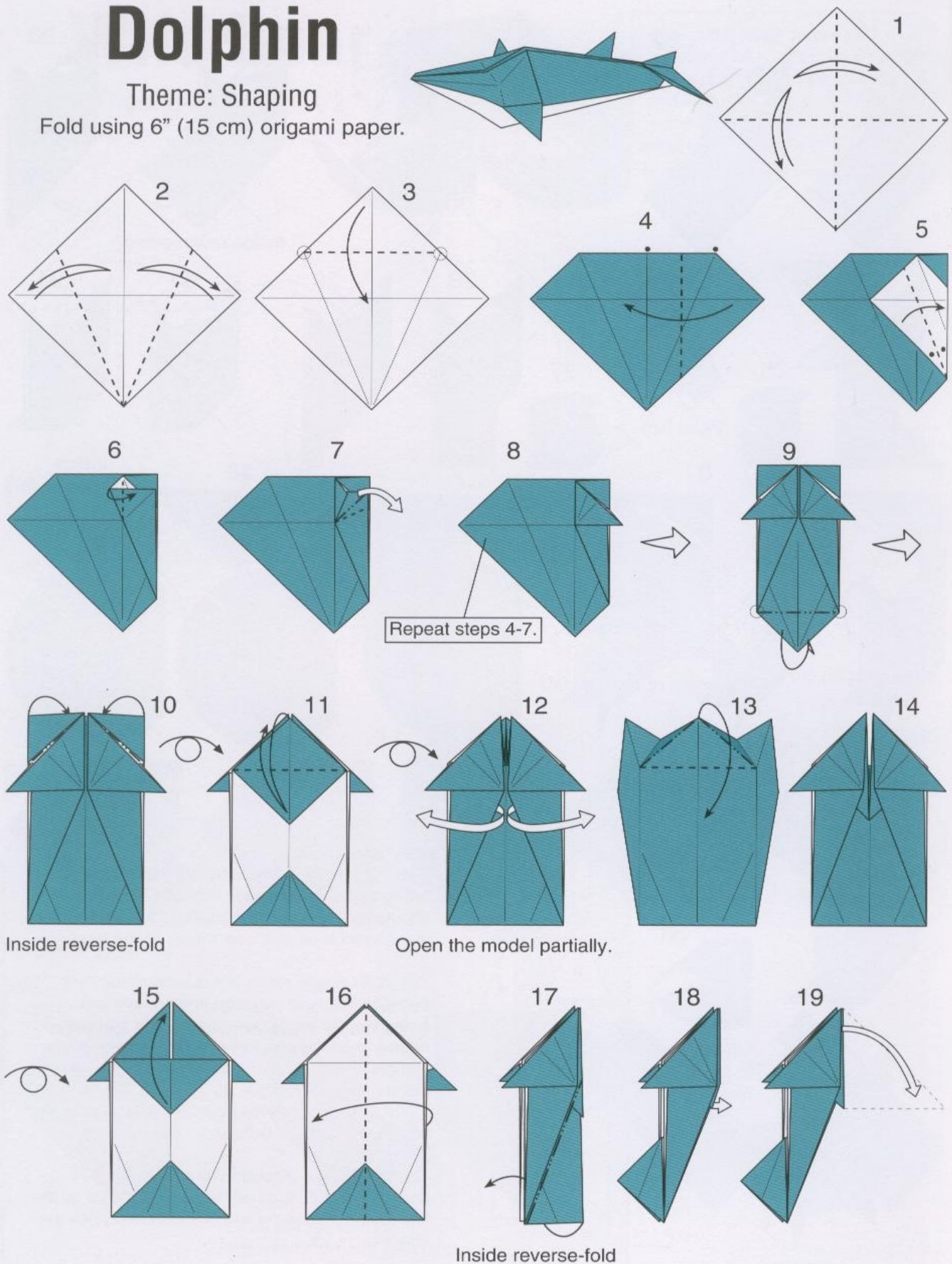

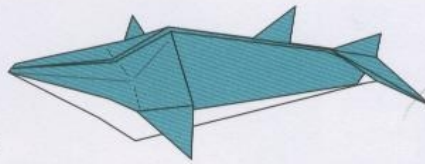
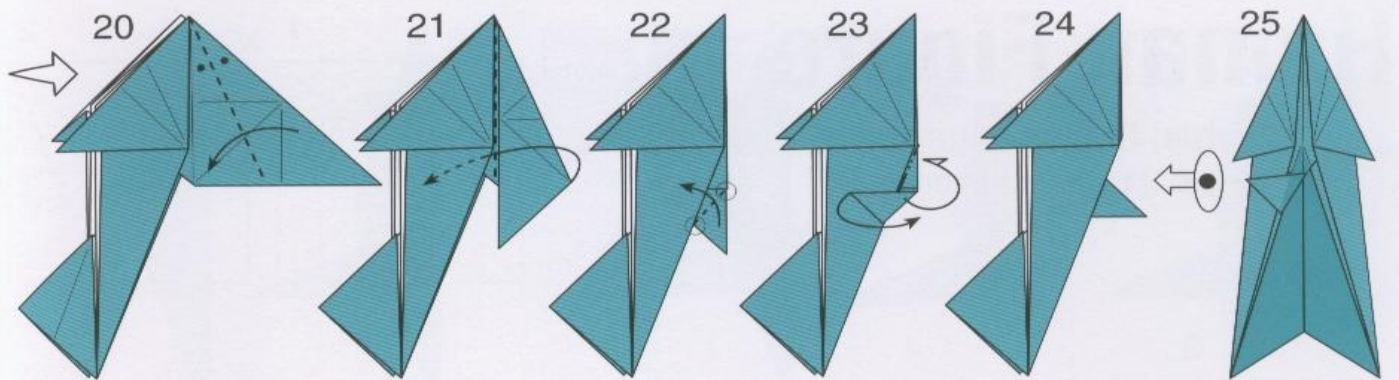

Tuck the small flap into the center pocket.

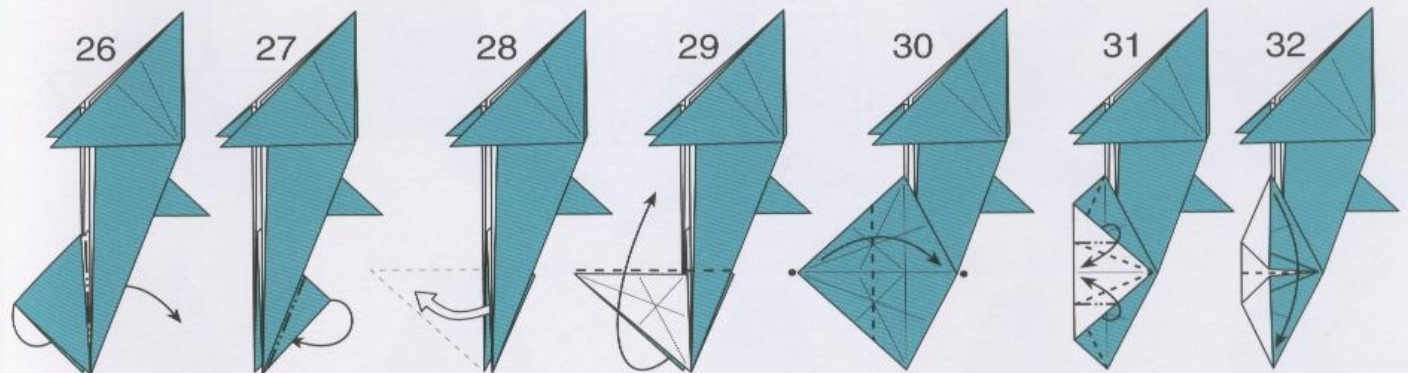

Inside reverse-fold

Inside reverse-fold

Swivel-fold

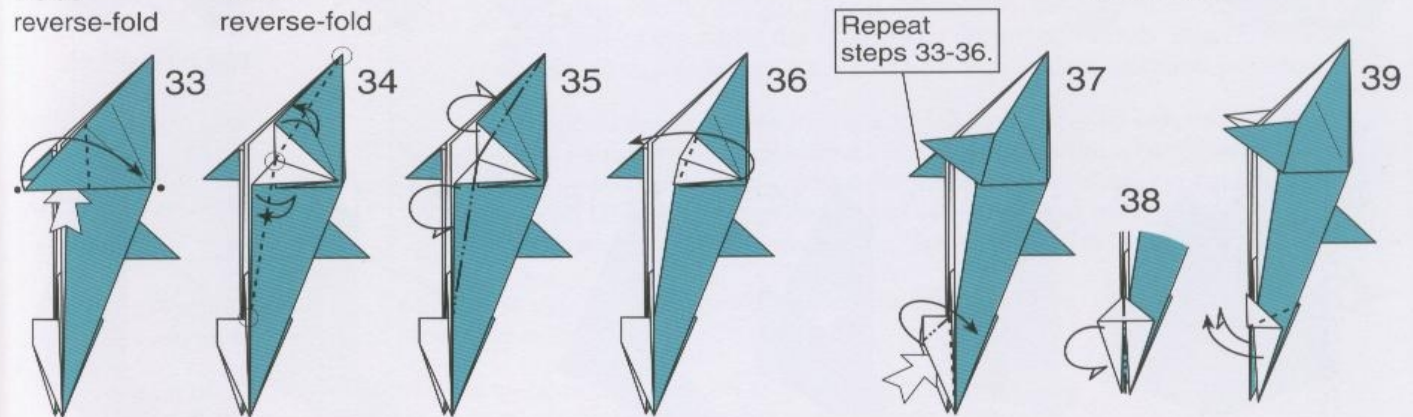

Repeat steps 33-36.

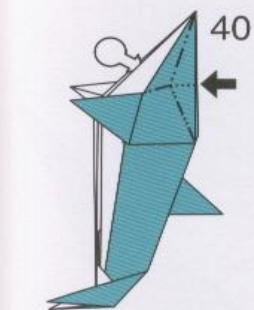

Using existing creases, pinch the head to make it 3D.

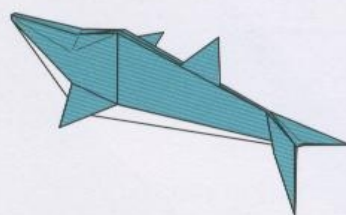

Make the anterior and tail fins almost horizontal to finish.

Shaping in origami

Pushing in and popping up, as with the head of this model, are techniques used to fold three-dimensional models. In this case, it is rather an extension of **half-open** folding and because of clear landmarks it is easy to fold.

Akira Yoshizawa, the father of modern origami, enhanced this technique to delicate craftsmanship. He also developed a technique called **wet folding**, where we damp the paper and fold before it dries to obtain stable curved surfaces. Though, I personally have very little experiences with that technique.